

# CITADEL 4s LED

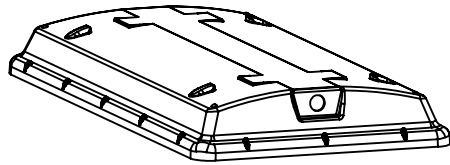

## CT4 HOUSINGS

- CT4s-HV5

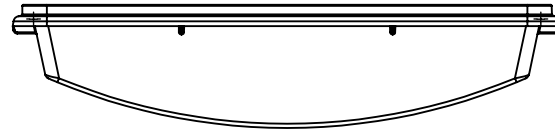

## DIFFUSERS

- CT4s-DIRA

*All lens material variations use same model.  
I.E. Acrylic/Polycarbonate/FR-50*

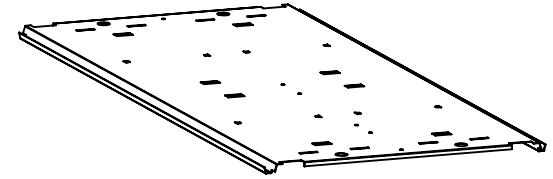

## CT4s LED FLAT BOARD TRAY

- CT4S-LED-BT1-4R-095
- CT4S-LED-BT1-4R-160

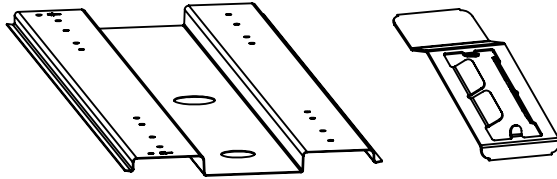

## DRIVER ATTACHMENT RAIL

- CT4s-2XDAR
- CT4s-2XDAR-CLIP

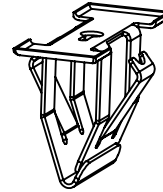

## BOARD RETENTION CLIP

- CT-LED-BRC-SM

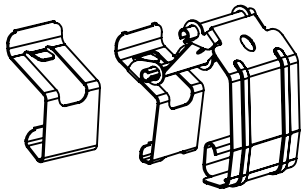

## Lens Retainers

- CT4s-LC
- CT4s-LATCHSS

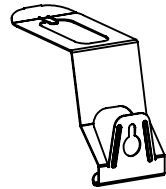

## MOUNTING STRAP

- CT4s-MS-SS
- CT4s-MS-ZP

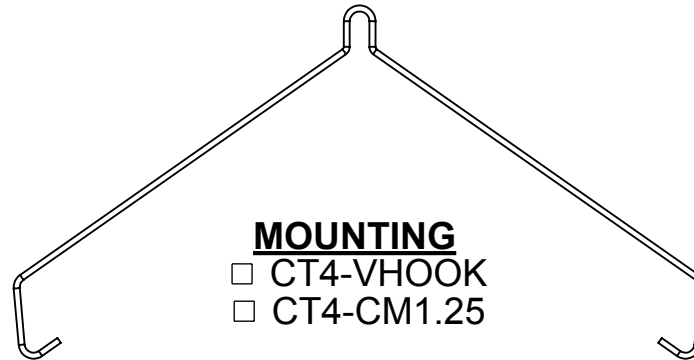

## MOUNTING

- CT4-VHOOK
- CT4-CM1.25

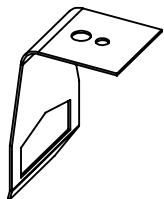

## GT RETAINER CLIP

- CT4-GTRC



## GT RC SCREW

- CT-SCRW

## UNIVERSAL GEAR TRAY SCREW

- CT-SCRW-UGT



## END PLUG

- CT-ENDPLUG-B

Citadel 4s LED

Parts List



1400 South Old Highway 141  
Fenton, MO. 63026  
PH (636) 600-4084 FX (636) 600-4108  
www.SLPlighting.com

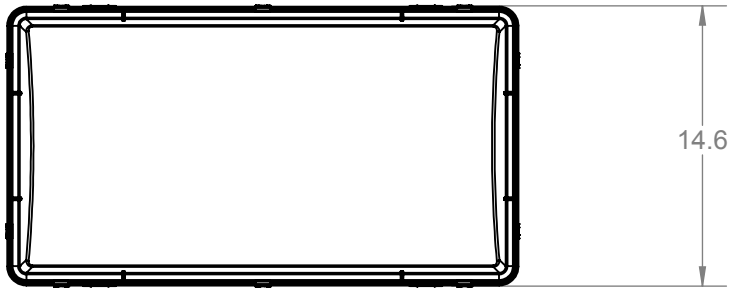
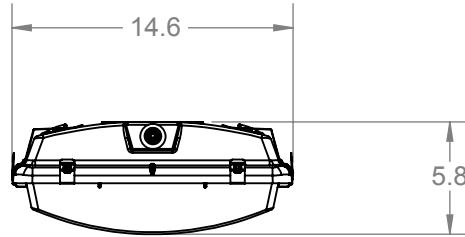
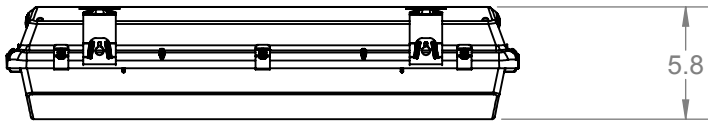
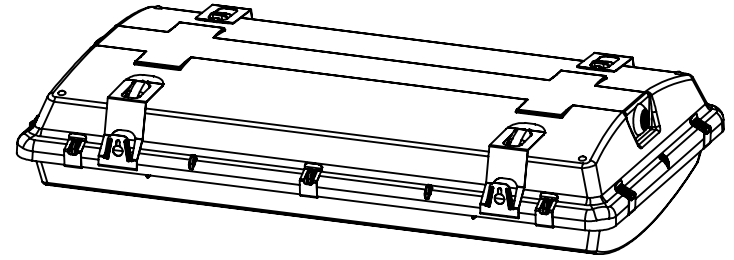
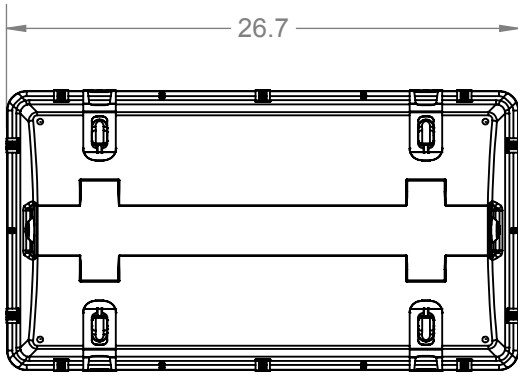

UNLESS OTHERWISE SPECIFIED:

DIMENSIONS ARE IN INCHES  
TOLERANCES AS NOTED  
FRACTIONAL  $\pm 1/16"$   
ANGULAR  $\pm 1^\circ$   
TWO PLACE DECIMAL  $\pm .060$   
THREE PLACE DECIMAL  $\pm .030$

INTERPRET GEOMETRIC TOLERANCING PER:

	NAME	DATE
DRAWN	-	xx/xx/xx
CHECKED	-	xx/xx/xx
ENG APPR.	-	xx/xx/xx
MFG APPR.	-	xx/xx/xx
Q.A.	-	xx/xx/xx

COMMENTS:

....

The information contained in this document is the confidential property of Koller Enterprises Inc. This information is to be used by the recipient only for the purpose of which it has been provided by Koller. This document and any information contained therein may not be reproduced or made available to any third party without the written authorization of Koller. No tooling to produce the product which is the subject of this document can be made without written authorization from Koller. Recipient's acceptance of this document is an acknowledgement of agreement to these terms.



1400 South Old Highway 141  
Fenton, MO. 63026

PH (636) 600-4084 FX (636) 600-4108  
www.SLPlighting.com

Part Weight	
Material	
Finish	
Drawn By: DWK	DATE : 9/11/2015

<b>CT4s Line Drawings</b>			
SIZE A	Scale 1:12	SHEET 1 OF 1	REV. A
DWG. No. CT4s LINE DRAWINGS			

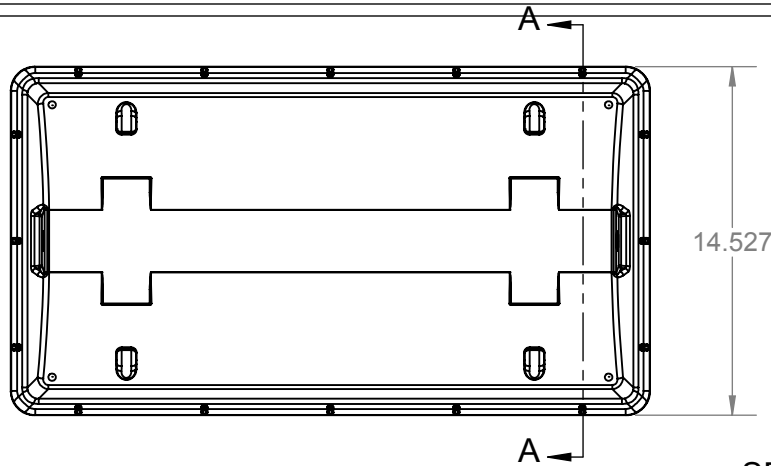

14.527

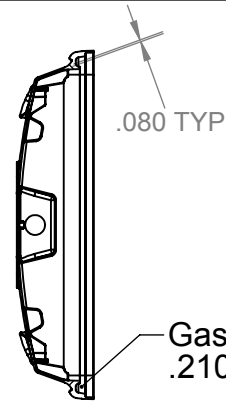

Gasket: 36 ± 4 Shore OO  
.210 ± .030" thickness

SECTION A-A

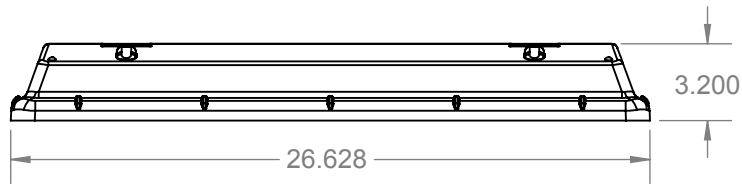

26.628

3.200

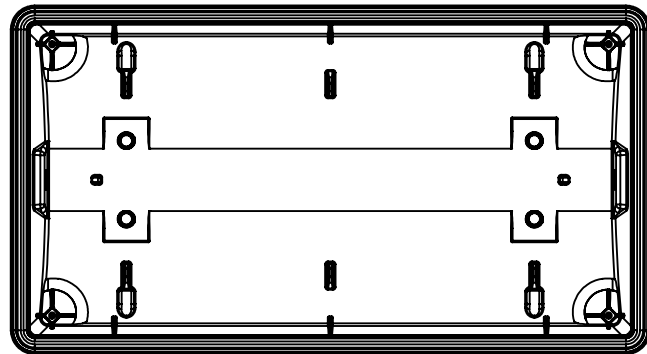
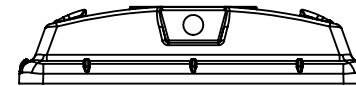

REVISIONS			
REV.	DESCRIPTION	DATE	APPROVED
A	Production	6.12.15	CSO

UNLESS OTHERWISE SPECIFIED:  
DIMENSIONS ARE IN INCHES  
TOLERANCES AS NOTED  
FRACTIONAL ± 1/16"  
ANGULAR ± 1°  
TWO PLACE DECIMAL ± .060  
THREE PLACE DECIMAL ± .030  
  
INTERPRET GEOMETRIC TOLERANCING PER:

	NAME	DATE
DRAWN	-	xx/xx/xx
CHECKED	-	xx/xx/xx
ENG APPR.	-	xx/xx/xx
MFG APPR.	-	xx/xx/xx
Q.A.	-	xx/xx/xx

COMMENTS:  
....

The information contained in this document is the confidential property of Koller Enterprises Inc. This information is to be used by the recipient only for the purpose of which it has been provided by Koller. This document and any information contained therein may not be reproduced or made available to any third party without the written authorization of Koller. No tooling to produce the product which is the subject of this document can be made without written authorization from Koller. Recipient's acceptance of this document is an acknowledgement of agreement to these terms.



1400 South Old Highway 141  
Fenton, MO. 63026

PH (636) 600-4084 FX (636) 600-4108  
www.SLPlighting.com

Part Weight		<b>CT4s-HV5</b>		
Material				
Finish	SIZE A	Scale 1:8	SHEET 1 OF 1	REV. A
Drawn By: CSO	DATE: 6/19/2015	DWG. No. CT4s-HV5		

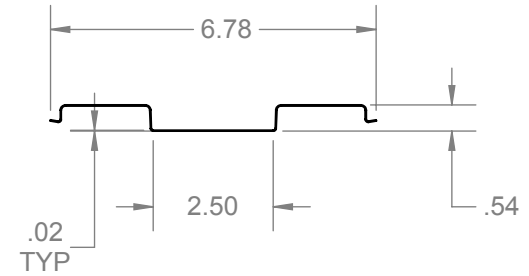
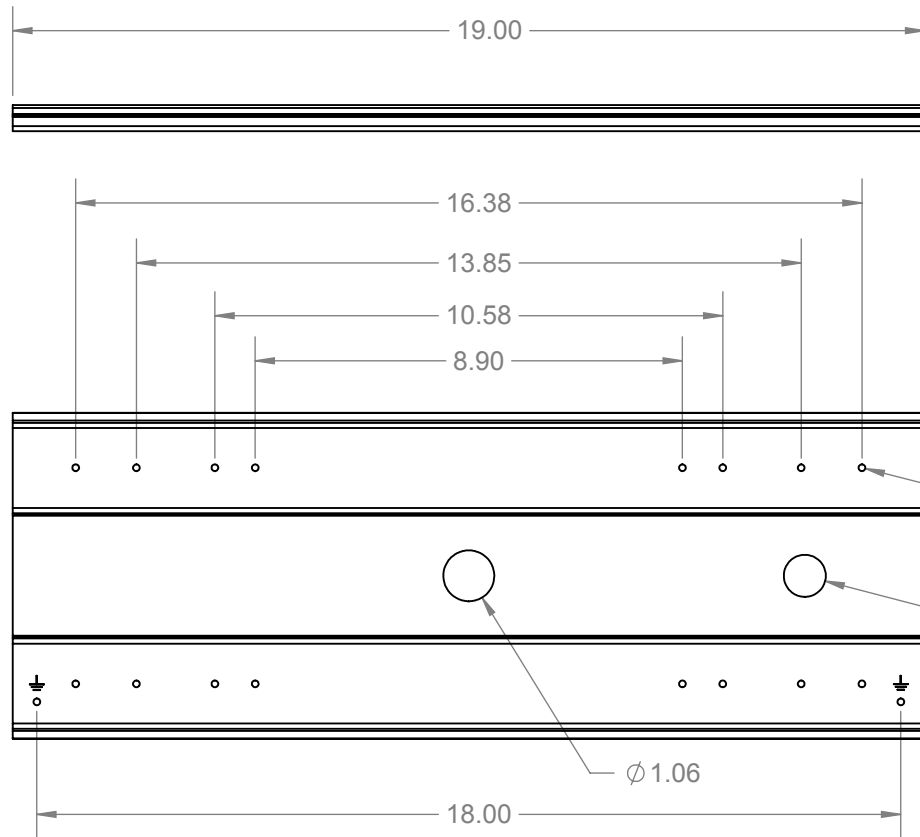
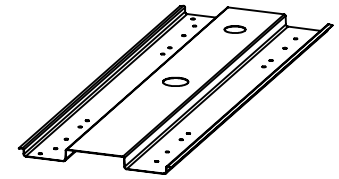

Ø .14

Ø .88

Ø 1.06

UNLESS OTHERWISE SPECIFIED:

DIMENSIONS ARE IN INCHES  
TOLERANCES AS NOTED  
FRACTIONAL ± 1/16"  
ANGULAR ± 1°  
TWO PLACE DECIMAL ± .060  
THREE PLACE DECIMAL ± .030

INTERPRET GEOMETRIC TOLERANCING PER:

	NAME	DATE
DRAWN	-	xx/xx/xx
CHECKED	-	xx/xx/xx
ENG APPR.	-	xx/xx/xx
MFG APPR.	-	xx/xx/xx
Q.A.	-	xx/xx/xx

COMMENTS:

....

The information contained in this document is the confidential property of Koller Enterprises Inc. This information is to be used by the recipient only for the purpose of which it has been provided by Koller. This document and any information contained therein may not be reproduced or made available to any third party without the written authorization of Koller. No tooling to produce the product which is the subject of this document can be made without written authorization from Koller. Recipient's acceptance of this document is an acknowledgement of agreement to these terms.



1400 South Old Highway 141  
Fenton, MO. 63026

PH (636) 600-4084 FX (636) 600-4108  
www.SLPlighting.com

Part Weight

Material  
020 PreCoat CRS

Finish

Drawn By:

CSO

DATE : 9/11/2015

SIZE  
A

Scale 1:4

SHEET 2 OF 2

REV.  
A

**CT4s-2XDAR**

DWG. No. CT4s-2XDAR

REVISIONS			
REV.	DESCRIPTION	DATE	APPROVED
A	Production	6.12.15	CSO

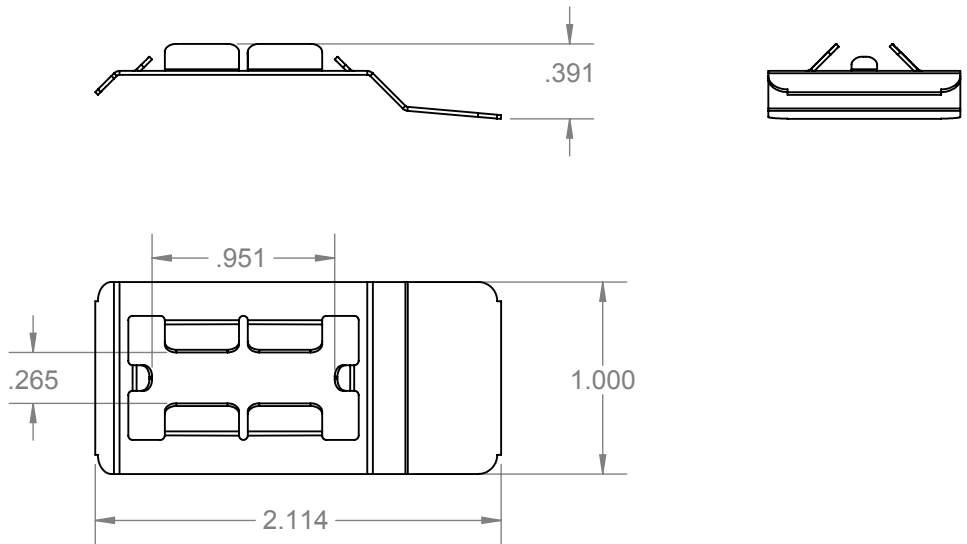

UNLESS OTHERWISE SPECIFIED:  
 DIMENSIONS ARE IN INCHES  
 TOLERANCES AS NOTED  
 FRACTIONAL ± 1/16"  
 ANGULAR ± 1°  
 TWO PLACE DECIMAL ± .060  
 THREE PLACE DECIMAL ± .030  
 INTERPRET GEOMETRIC TOLERANCING PER:

	NAME	DATE
DRAWN	-	xx/xx/xx
CHECKED	-	xx/xx/xx
ENG APPR.	-	xx/xx/xx
MFG APPR.	-	xx/xx/xx
Q.A.	-	xx/xx/xx

COMMENTS:  
 ....

The information contained in this document is the confidential property of Koller Enterprises Inc. This information is to be used by the recipient only for the purpose of which it has been provided by Koller. This document and any information contained therein may not be reproduced or made available to any third party without the written authorization of Koller. No tooling to produce the product which is the subject of this document can be made without written authorization from Koller. Recipient's acceptance of this document is an acknowledgement of agreement to these terms.



1400 South Old Highway 141 Fenton, MO. 63026 PH (636) 600-4084 FX (636) 600-4108 www.SLPlighting.com

Part Weight		<b>CT-2XDAR-CLIP</b>	
Material			
C1050 Steel		SIZE	REV.
Finish		A	A
HT Phosphate Coating		Scale 1:1	SHEET 1 OF 1
Drawn By:	CSO	DATE : 6/19/2015	DWG. No. CT-2XDAR-CLIP

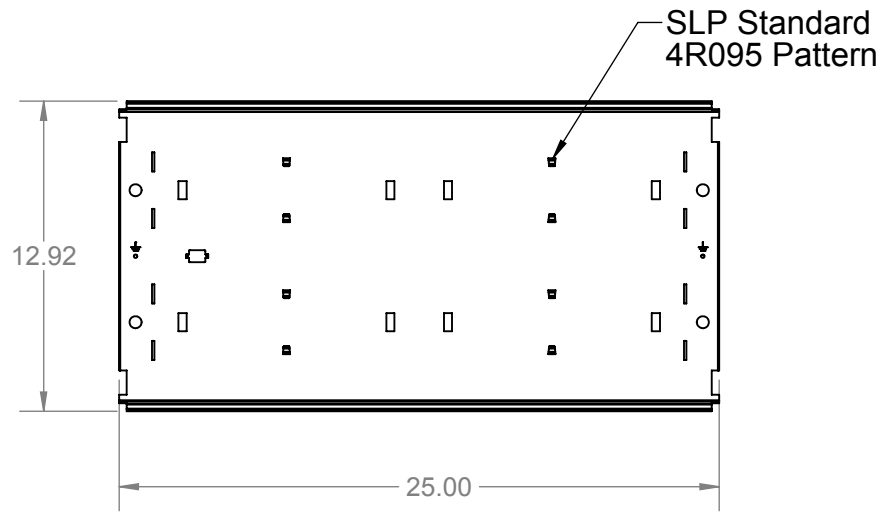
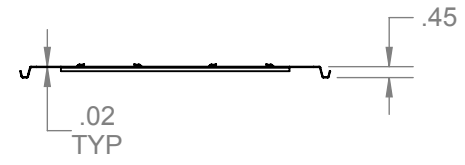
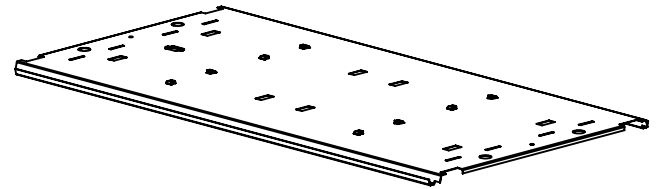

UNLESS OTHERWISE SPECIFIED:  
 DIMENSIONS ARE IN INCHES  
 TOLERANCES AS NOTED  
 FRACTIONAL ± 1/16"  
 ANGULAR ± 1°  
 TWO PLACE DECIMAL ± .060  
 THREE PLACE DECIMAL ± .030  
 INTERPRET GEOMETRIC TOLERANCING PER:

	NAME	DATE
DRAWN	-	xx/xx/xx
CHECKED	-	xx/xx/xx
ENG APPR.	-	xx/xx/xx
MFG APPR.	-	xx/xx/xx
Q.A.	-	xx/xx/xx

COMMENTS:  
 ....

The information contained in this document is the confidential property of Koller Enterprises Inc. This information is to be used by the recipient only for the purpose of which it has been provided by Koller. This document and any information contained therein may not be reproduced or made available to any third party without the written authorization of Koller. No tooling to produce the product which is the subject of this document can be made without written authorization from Koller. Recipient's acceptance of this document is an acknowledgement of agreement to these terms.



1400 South Old Highway 141 Fenton, MO. 63026 PH (636) 600-4084 FX (636) 600-4108 www.SLPlighting.com

Part Weight	CT4s-LED-BT1-4R095		
Material	020 PreCoat CRS		
Finish	SIZE A	Scale 1:8	SHEET 2 OF 2 REV. A
Drawn By: CSO	DATE: 9/11/2015	DWG. No. CT4s-LED-BT1-4R095	

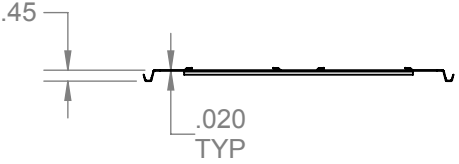
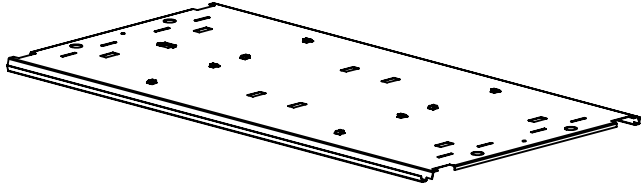

SLP Standard  
4R160 Pattern

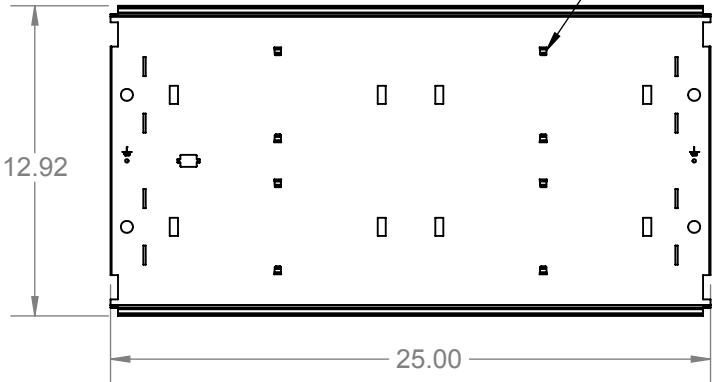

UNLESS OTHERWISE SPECIFIED:  
DIMENSIONS ARE IN INCHES  
TOLERANCES AS NOTED  
FRACTIONAL ± 1/16"  
ANGULAR ± 1°  
TWO PLACE DECIMAL ± .060  
THREE PLACE DECIMAL ± .030  
  
INTERPRET GEOMETRIC TOLERANCING PER:

	NAME	DATE
DRAWN	-	xx/xx/xx
CHECKED	-	xx/xx/xx
ENG APPR.	-	xx/xx/xx
MFG APPR.	-	xx/xx/xx
Q.A.	-	xx/xx/xx
COMMENTS:		
....		

The information contained in this document is the confidential property of Koller Enterprises Inc. This information is to be used by the recipient only for the purpose of which it has been provided by Koller. This document and any information contained therein may not be reproduced or made available to any third party without the written authorization of Koller. No tooling to produce the product which is the subject of this document can be made without written authorization from Koller. Recipient's acceptance of this document is an acknowledgement of agreement to these terms.



1400 South Old Highway 141  
Fenton, MO. 63026  
PH (636) 600-4084 FX (636) 600-4108  
www.SLPlighting.com

Part Weight	CT4s-LED-BT1-4R160		
Material	020 PreCoat CRS		
Finish	SIZE A	Scale 1:8	SHEET 2 OF 2
Drawn By:	CSO	DATE : 9/11/2015	REV. A
DWG. No. CT4s-LED-BT1-4R160			

REVISIONS			
REV.	DESCRIPTION	DATE	APPROVED
A	Production	6.12.15	CSO

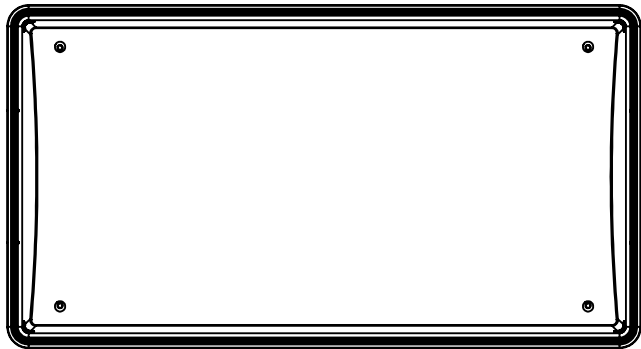
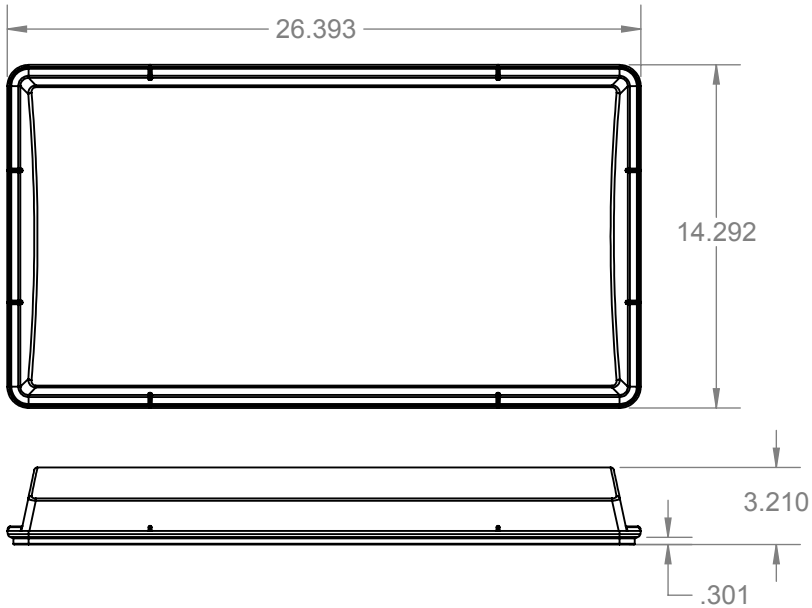

CT4s-DIRA:Clear Acrylic  
 CT4s-DIRA-FR50:Frosted Acrylic  
 CT4s-DP:Clear Polycarbonate  
 CT4s-DP-F50:Frosted Polycarbonate

UNLESS OTHERWISE SPECIFIED:  
 DIMENSIONS ARE IN INCHES  
 TOLERANCES AS NOTED  
 FRACTIONAL ± 1/16"  
 ANGULAR ± 1°  
 TWO PLACE DECIMAL ± .060  
 THREE PLACE DECIMAL ± .030  
 INTERPRET GEOMETRIC TOLERANCING PER:

	NAME	DATE
DRAWN	-	xx/xx/xx
CHECKED	-	xx/xx/xx
ENG APPR.	-	xx/xx/xx
MFG APPR.	-	xx/xx/xx
Q.A.	-	xx/xx/xx

COMMENTS:  
 ....

The information contained in this document is the confidential property of Koller Enterprises Inc. This information is to be used by the recipient only for the purpose of which it has been provided by Koller. This document and any information contained therein may not be reproduced or made available to any third party without the written authorization of Koller. No tooling to produce the product which is the subject of this document can be made without written authorization from Koller. Recipient's acceptance of this document is an acknowledgement of agreement to these terms.



1400 South Old Highway 141 Fenton, MO. 63026 PH (636) 600-4084 FX (636) 600-4108 www.SLPlighting.com

Part Weight		CT4s Lens		
Material See above				
Finish	SIZE A	Scale 1:8	SHEET 1 OF 1	REV. A
Drawn By: CSO	DATE: 6/19/2015	DWG. No. CT4s-LENS		



REVISIONS			
REV.	DESCRIPTION	DATE	APPROVED
A	Production	6.12.15	CSO

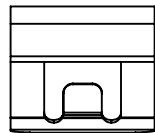
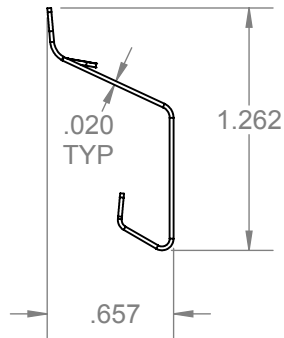
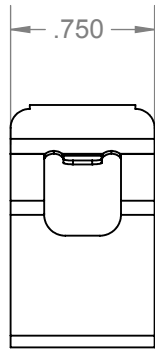

UNLESS OTHERWISE SPECIFIED:

DIMENSIONS ARE IN INCHES  
TOLERANCES AS NOTED  
FRACTIONAL  $\pm 1/16"$   
ANGULAR  $\pm 1^\circ$   
TWO PLACE DECIMAL  $\pm .060$   
THREE PLACE DECIMAL  $\pm .030$

INTERPRET GEOMETRIC TOLERANCING PER:

	NAME	DATE
DRAWN	-	xx/xx/xx
CHECKED	-	xx/xx/xx
ENG APPR.	-	xx/xx/xx
MFG APPR.	-	xx/xx/xx
Q.A.	-	xx/xx/xx

COMMENTS:

....

The information contained in this document is the confidential property of Koller Enterprises Inc. This information is to be used by the recipient only for the purpose of which it has been provided by Koller. This document and any information contained therein may not be reproduced or made available to any third party without the written authorization of Koller. No tooling to produce the product which is the subject of this document can be made without written authorization from Koller. Recipient's acceptance of this document is an acknowledgement of agreement to these terms.



1400 South Old Highway 141  
Fenton, MO. 63026

PH (636) 600-4084 FX (636) 600-4108  
www.SLPlighting.com

Part Weight		<b>CT4s-LC</b>	
Material: <b>316 SS 1/2 Hard</b>			
Finish	SIZE A	Scale 1:1	REV. A
Drawn By: CSO	DATE: 6/19/2015	SHEET 1 OF 1	
DWG. No. CT4s-LC			

REVISIONS			
REV.	DESCRIPTION	DATE	APPROVED
A	Production	6.12.15	CSO

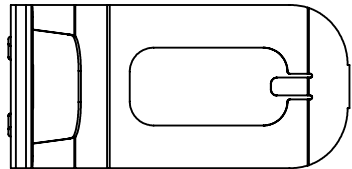
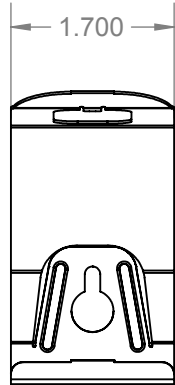
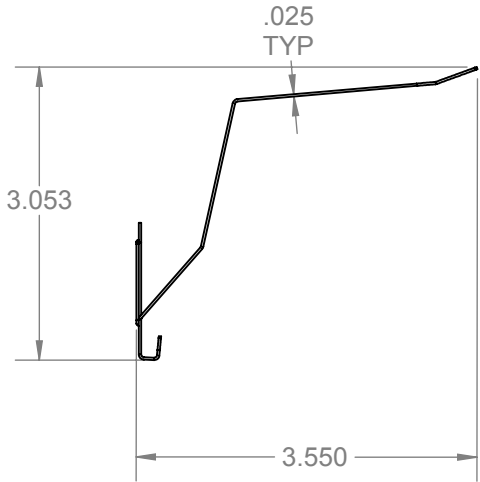

SS: 316 SS 1/2 Hard  
 ZP: HSLA Zinc Electroplated (ASTM B633)

UNLESS OTHERWISE SPECIFIED:  
 DIMENSIONS ARE IN INCHES  
 TOLERANCES AS NOTED  
 FRACTIONAL ± 1/16"  
 ANGULAR ± 1°  
 TWO PLACE DECIMAL ± .060  
 THREE PLACE DECIMAL ± .030  
 INTERPRET GEOMETRIC TOLERANCING PER:

	NAME	DATE
DRAWN	-	xx/xx/xx
CHECKED	-	xx/xx/xx
ENG APPR.	-	xx/xx/xx
MFG APPR.	-	xx/xx/xx
Q.A.	-	xx/xx/xx

COMMENTS:  
 ....

The information contained in this document is the confidential property of Koller Enterprises Inc. This information is to be used by the recipient only for the purpose of which it has been provided by Koller. This document and any information contained therein may not be reproduced or made available to any third party without the written authorization of Koller. No tooling to produce the product which is the subject of this document can be made without written authorization from Koller. Recipient's acceptance of this document is an acknowledgement of agreement to these terms.



1400 South Old Highway 141 Fenton, MO. 63026 PH (636) 600-4084 FX (636) 600-4108 www.SLPlighting.com

Part Weight	<b>CT4s-MS-SS</b> <b>CT4s-MS-ZP</b>			
Material				See Above
Finish	SIZE A	Scale 1:2	SHEET 1 OF 1	REV. A
Drawn By: CSO	DATE: 6/19/2015	DWG. No. CT4s-MS		