

Shaped for unique lighting applications, the Profile I is the first of its series of uniquely shaped enclosures. The foundation is a versatile internal component system designed to stay the same which increases speed to market with reduced tooling on future housing designs in the Profile series.

2'



4'



8'



Features & Benefits

- Designed for LEDs
- Familiar economical mounting options
- UL (f1) rated material co-extruded housing and lens
- 2 ft., 4 ft. and 8 ft. length options
- Flat internal board tray for use with linear Zhaga boards
- Electrical enclosure encapsulates all higher voltage components
- All components of encapsulating electrical enclosure are made of no less than 5VA approved material
- Passage for Class 2 wiring through the board tray from the LED driver to the LED board is protected via grommet
- UL evaluated for 25° C and 40° C

Applications

- Low bay areas requiring a linear LED enclosure
- General lighting
- Supermarkets
- Office lighting
- Garden centers
- Food processing
- Warehouses
- Subways
- Cold storage

Certifications

- UL wet location
- IP65, IP66
 - SLP vent plug required
- RoHS

Product offering and specifications subject to change without notice

Assembly

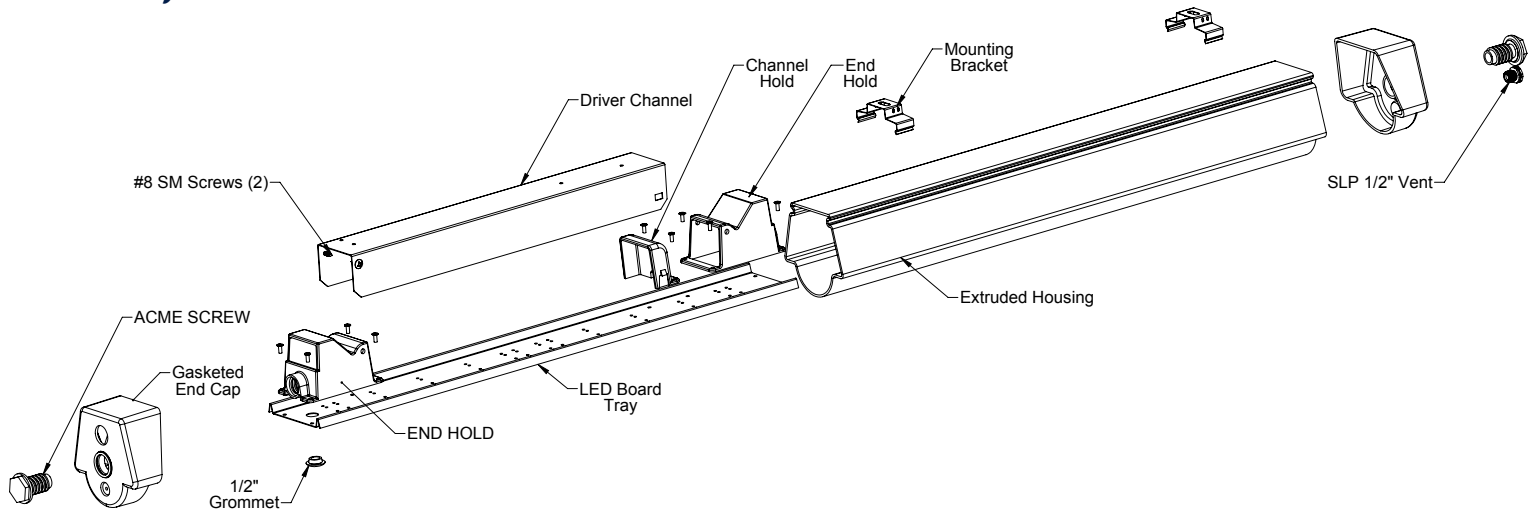

Components

Component	Description	Standard Material	Pieces Required per Assembly			Available Options
			2'	4'	8'	
Housing Extrusion	Co-extruded housing and lens		1	1	1	Frosted or Black Polycarbonate
Board Tray	Supports LED boards	Cold rolled steel	1	1	1	Linear Zhaga for all lengths
Driver Channel	Contains driver	Cold rolled steel	1	1	1	16" driver channel for 2' unit 20" driver channel for 4' and 8' unit Raceway for 2' or 4' through wiring
End Hold	Locks in driver channel to board tray	Black noryl	2	2	2	
Channel Hold	Holds driver channel in place	Black noryl	1	1	1	
End Caps	Enclose the unit	Noryl	2	2	2	Black or white
Acme Screw	Holds on the end cap	Noryl	2	2	2	Black or white
Mounting Bracket	Snap on mounting for easy installation and mounting	316 stainless steel	2	2	2	Optional hanging bail accessory optional drilled for threaded rod pendant
Safety Bail	Snaps around the fixture to add extra security for high traffic areas	316 stainless steel	2	2	2	Optional
SLP #8 Screws	Driver channel attachment to endhold		2	2	2	(Optional additional 2 per 2' section of LED board to attach board to tray)
Wire Grommet	Protects wires from stripping on board tray edge		1	1	1	
SLP Vent Plug	End plug with a vent		1	1	1	Required for IP65 and IP66 rating

Product offering and specifications subject to change without notice

Housing Extrusions

Length	Material	Part #	PCS / CTN	WT / CTN	Full Skid Quantity
2'	Black polycarbonate housing extrusion	PRF-S1-HE-BLK-P-2	5		100
4'	Black polycarbonate housing extrusion	PRF-S1-HE-BLK-P-4	5		100
8'	Black polycarbonate housing extrusion	PRF-S1-HE-BLK-P-8	5		80
2'	Frosted polycarbonate housing extrusion	PRF-S1-HE-FRST-P-2	5		100
4'	Frosted polycarbonate housing extrusion	PRF-S1-HE-FRST-P-4	5		100
8'	Frosted polycarbonate housing extrusion	PRF-S1-HE-FRST-P-8	5		80

Board Tray

Length	Material	Part #	PCS / CTN	WT / CTN	Full Skid Quantity
2'	Linear Zhaga 2' LED board tray	PRF-BT1-LZH-2			
4'	Linear Zhaga 4' LED board tray	PRF-BT1-LZH-4			
8'	Linear Zhaga 8' LED board tray	PRF-BT1-LZH-8			

Driver Channel

Length	Material	Part #	PCS / CTN	WT / CTN	Full Skid Quantity
16"	16" CRS driver channel for 2'	PRF-DC1-16	40		
20"	20" CRS driver channel for 4' and 8'	PRF-DC1-20	40		
2'	2' raceway option for through wiring	PRF-RW1-2			
4'	4' raceway option for through wiring	PRF-RW1-4			

Hardware

Component	Part #	PCS / BAG	PCS / CTN	WT / CTN
End Hold	PRF-EH-BLK-N		210	21 lbs / 9.52 kg
Driver Channel Hold	PRF-CH-BLK-N		1,200	
Gasketed End Caps with D-Ring Black	PRF-S1-EC-BLK-N-S		160	22 lbs / 9.97 kg
Gasketed End Caps with D-Ring White	PRF-S1-EC-WHT-N-S		160	22 lbs / 9.97 kg
Acme Screw	PRF-AS-BLK-N	80	160	
Optional Wire Grommet	SLP-GRMT-0500	200	1,000	
#8 LED Screw	SLP-SCRW-850	100		
SLP Vent Plug	SLP-ENDPLUG-B-V	100		

Mounting Brackets

Mounting Bracket	Material	Part #	PCS / BAG	PCS / CTN	WT/CTN
Mounting Bracket (2 per unit)	Stainless steel	PRF-MB		1,200	
Optional Safety Bail	Stainless steel	PRF-S1-SB		500	

Mounting Accessories

Accessory	Material	Part #	PCS / BAG	PCS / CTN	WT/CTN
Chain Hang: Mounting Bail (2 per unit)	Stainless steel	CT-BAIL	100	5,000	27 lbs / 12.2 kg

Product offering and specifications subject to change without notice