



HI-CELL™ OPTICS FOR T5

T5

TRIMMABLE LENGTH FOR CUSTOM FIT 2' AND 4' LENGTHS

Build your luminaires around the most advanced optics available.

Nominal	Maximum length	Minimum length
600mm	608mm	545mm
2'	23.92"	21.46"
1200mm	1215mm	1153mm
4'	47.84"	45.37"

- Reduced product development time.
- Reduced tooling investment.
- Reduced inventory investment.
- Reduced scrap expense.
- Bring product to market faster.
- Increase sales opportunities.



SLP is an international organization that has achieved the fine balance of craftsmanship and state of the art technology that fosters the ability to produce innovative new products. By developing synergies with respected designers SLP is able to introduce exciting new products that meet the demanding needs of a world market. HI-CELL™ brings to market the benefits valued by manufacturers, the efficiency demanded by an energy hungry world and the luminance control that is required for a healthy visual environment.

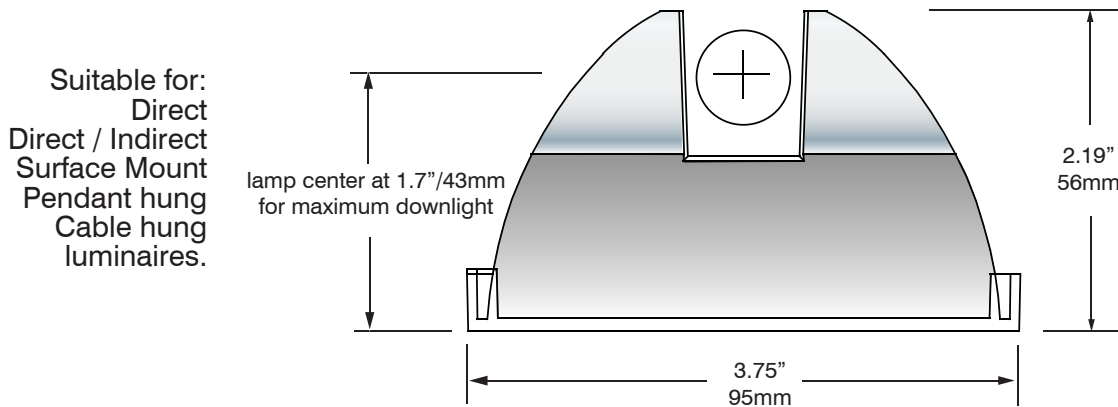

	FINISH	2' / 600mm	4' / 1200mm	WT/CTN
ACRYLIC	Specular Permalux	HCT5-A-600-P	HCT5-A-1200-P	26lbs/ 11.79kg
	ALUMA-LUX (Semi-Specular)	HCT5-A-600-AL	HCT5-A-1200-AL	26lbs/ 11.79kg
	White	HCT5-A-600-W	HCT5-A-1200-W	26lbs/ 11.79kg
POLYCARBONATE	Specular Permaulx	HCTT-PC-600-P	HCT5-PC-1200-P	25lbs/ 11.33kg
	ALUMA-LUX (Semi-Specular)	HCT5-PC-600-AL	HCT5-PC-1200-AL	25lbs/ 11.33kg
CTN/QTY		30	15	

Product offering and specifications subject to change without notice.

SLP LIGHTING

PHONE: 636.600.4084

| 800.248.0224

FAX: 636.600.4108

www.slplighting.com

V080910